

model: G7N

## ABOUT THE KILN

The kilns are built using the latest insulating materials and equipment. These materials have many times the insulating value of bricks and are much lighter. They can withstand thermal shock (i.e. fast temperature changes) exceptionally well. There are other fundamental differences between ceramic fibre and brick. Certain changes will occur after the kiln has been fired. Small gaps will appear between the boards and slight warping might occur. This is normal and not detrimental to the performance or longevity of the kiln. Ceramic fibre expands during firing and the gaps that appear after the first firing are for this expansion. Also small cracks may appear on the hot face (as on a brick kiln). The insulation is of a multi-layered design and heat will not pass through. The fibre is translucent and red heat is sometimes seen from the outside and around the door seal. It is most important to protect the insulation from mechanical damage, i.e. when loading pots and bats and when moving the kiln. It is better to carry the kiln rather than trolley it. Extreme care must be taken if moving the kiln after it has been fired.

## SITING THE KILN

It is a good idea to site the kiln on a stand or some bricks. Important If siting the kiln directly on a combustible floor (e.g. wooden) first place a layer of asbestos type board (e.g. superlux) on the floor. The burners give off a large amount of radiant heat and this could cause a fire hazard without this protection. The base should be firm, flat and level. If there is movement it could cause the metal case to warp.

If sited outdoors a canopy should be built. If this is not possible a plastic sheet should be used to cover the kiln when not in use. It is also worth noting that mice will climb into the kiln and tear off the fibre for nesting material. Therefore make sure that all the exits from the kiln are blocked when not in use. (i.e. the chimney, spy holes and burner ports.) If used indoors make sure rain cannot run down the vent. pipe. Adequate ventilation is essential for any gas appliance. Grilles should be fitted to allow fresh air into the room. Leave a window or door open during firing. Make sure there are no combustible materials near the kiln and always leave a minimum of 8"/200mm air gap around the kiln. If the walls or ceiling is made of combustible material this should be lined with asbestos type board. Important Do not put any material directly against the outside of the kiln (e.g. asbestos type board). This will cause the metal to become hot and deform.

It is worth considering fitting Carbon Monoxide and gas leak alarms. These are battery or mains powered units that are fitted in the same room as the kiln. They will sound an alarm if these dangerous gases are emitted into the room. They are available at low cost from most DIY shops. A fire extinguisher is also a good thing to have.

## PRE FITTING CHECK LIST

The kiln will come with certain parts separate. These will need correct assembly and fitting. These parts are (depending on model and ancillaries)

- 1) Stand (either comes assembled or to be assembled - depending on model)
- 2) Burner(s) to be fitted. (Depending on model)
- 3) Burners to be checked for position
- 4) Ventilation hood (to be assembled and fitted)
- 5) Ventilation pipe (to be fitted)
- 6) Gas feed pipe (to be connected and fitted)
- 7) Pyrometer and thermocouple (to be wired and fitted)
- 8) Other control equipment-heat fuse, cut off, automatic control. (to be wired and fitted)
- 9) Door securing nuts to be loosened or removed.

To assemble the stand the legs are pressed into the top supports with the shelf fixing holes facing the front. The legs might need tapping into the top support, using a hammer and a piece of wood. (remove the feet first.) Next the shelf is fitted using the four nuts and bolts provided. The above operation is easiest done with the stand being assembled upside down. When the stand is upright the feet should be adjusted to give a level base.

J series kilns: the burner(s) are now loosely fitted to the stand.

The kiln may now be placed on the stand. After checking that the kiln is level and does not rock on the stand, or the stand on the floor, the locking nuts on the feet should be locked using a spanner.

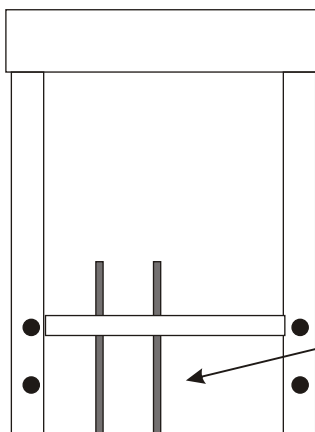
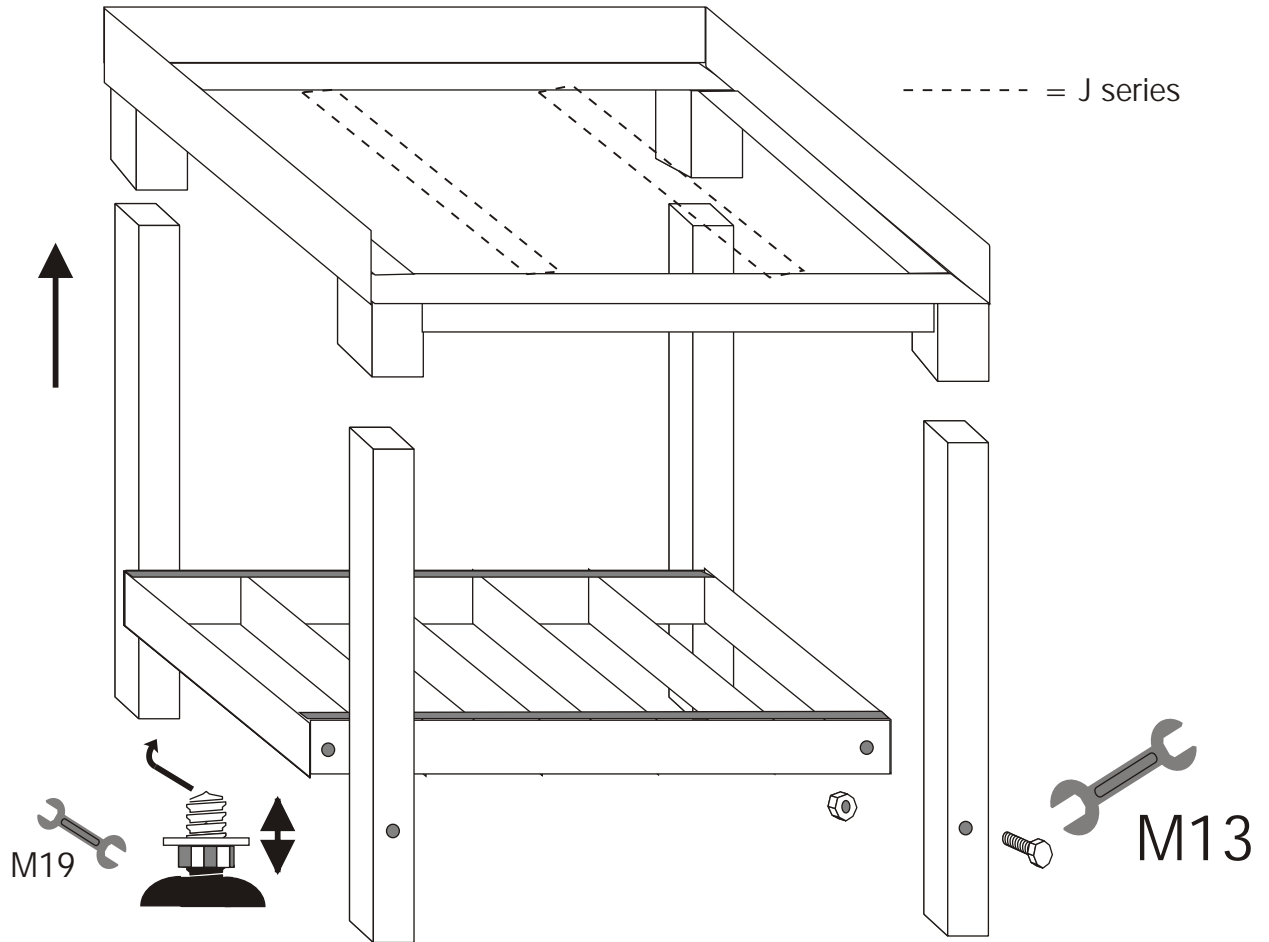

The stand is assembled by placing the top part upside down on the floor, and pushing the legs into the sockets. Take note of the shelf fixing hole alignment. The shelf can then be fixed as shown above. There are two positions to fix the shelf. Normally it is fixed on the lower holes. However if you wish to use the straps on the shelf as dividers to store vertical kiln bats or sheets of glass then the upper holes are best.

The feet are adjustable to allow for uneven floors.

The kiln will have been supplied with the burner(s) fitted or they will have been fitted to the stand as last page. Before connecting the gas pipe, check that the burner(s) are central in the burner slot(s). If not loosen retaining bar screws and move burner(s) to a central position. (see drawing). Next connect gas pipe to gas connection point. (On some natural gas models, the pressure governor and main gas tap are supplied separately. These should be fitted on to the burner so that the tap handle is vertical) The gas pipe is then connected to the union. Before lighting the burner(s) test all connections for leaks using soapy water. Do this check before placing the kiln. A competent engineer should carry out gas fitting work. On natural gas models ensure that the feed pipe is large enough to allow for correct flow rate. Do not assume that the gas feed pipe can be the same size as the final connection (1/2" BSP) (Contact us if in doubt) The gas pipe should be supported from the floor or wall to prevent damage. A main gas tap should be installed near the kiln. If the kiln is used indoors IT IS ESSENTIAL that a ventilation hood and piping is used. All piping should run to the outside of the building. All piping and flue should be installed by a qualified engineer and conform with local regulations.

## Electrical connection.

If the kiln is fitted with mains ignition system and/or fan(s) (turbo), these should be wired from a socket outlet fitted with a 3amp fuse. The earth wire (green/yellow) must be connected, brown = live, blue = neutral. Check that the main flex does not run near the burner or get too hot.

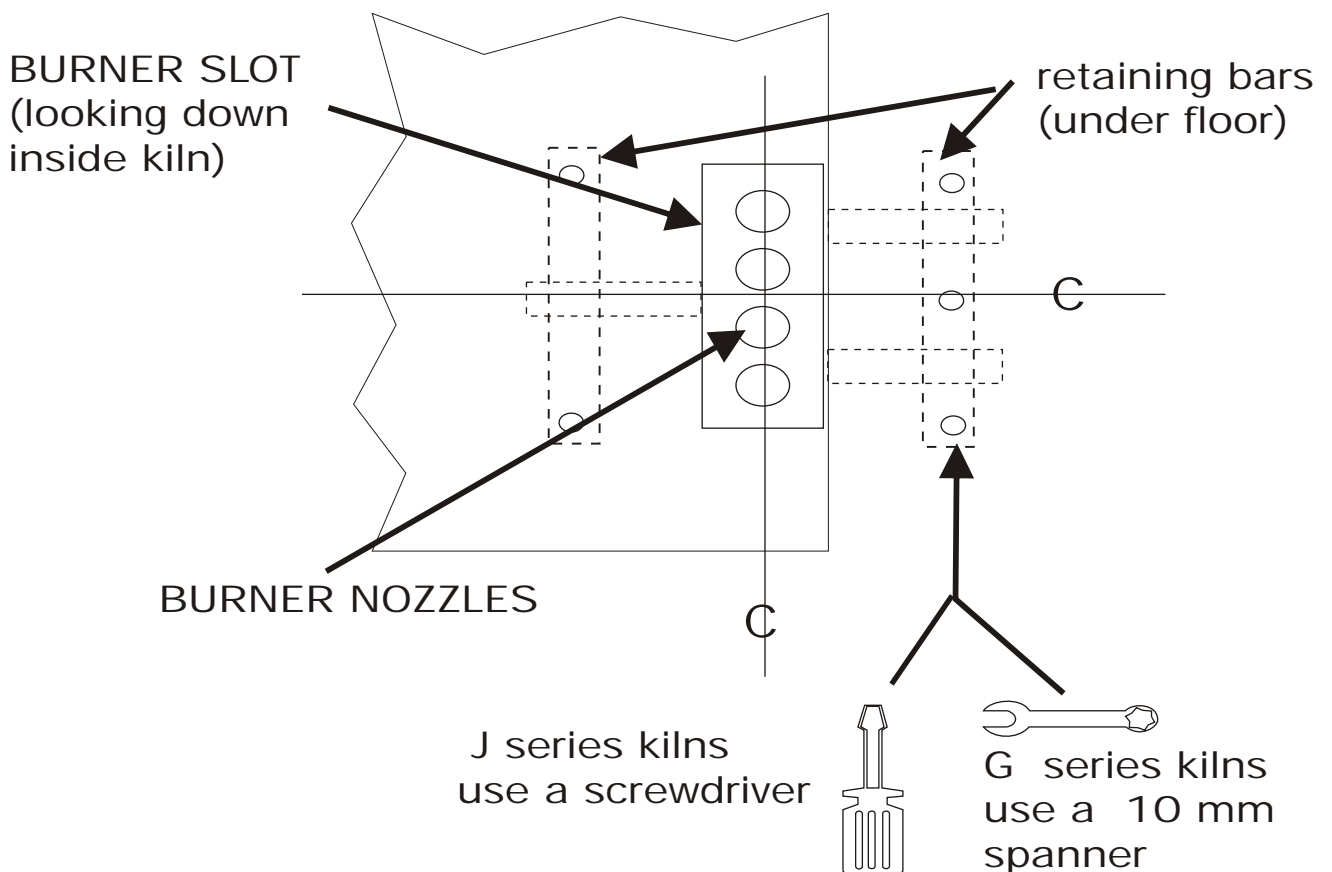

Extreme care must be taken when placing bats or pots into the kiln. The walls are liable to be damaged if this is not observed. It is advisable to use the floor bat(s) to protect the brick floor from glaze spillage. It is a good idea to place the floor bat(s) on top of discs or small pieces of bats (approx.

3"/75mm square). - Broken pieces of old bats are ideal for this. These should be put directly underneath the point where the props will be placed. This will spread the load on the brick floor and also allow heat to pass under the bats.

### HEAT DISTRIBUTION

The usual system of varying the heat distribution throughout the kiln is shown on the diagram A below. The important factor is the gap between the bat and the side wall(s) above the burner(s). If you require more heat at the bottom of the kiln the gap should become progressively smaller towards the top of the kiln. (as shown on diagram B) If more heat is required at the top the gap should become larger.

It is important to appreciate that correct heat distribution is something that requires a certain amount of experimentation. It is most important to use cones for final turn off point. A number of sets of cones should be used throughout the kiln for the first few firings. A log should be kept, noting shelf or baffle positions and results. Time spent on this matter in the first six or so firings, will be rewarded with easy dependable firings in the future.

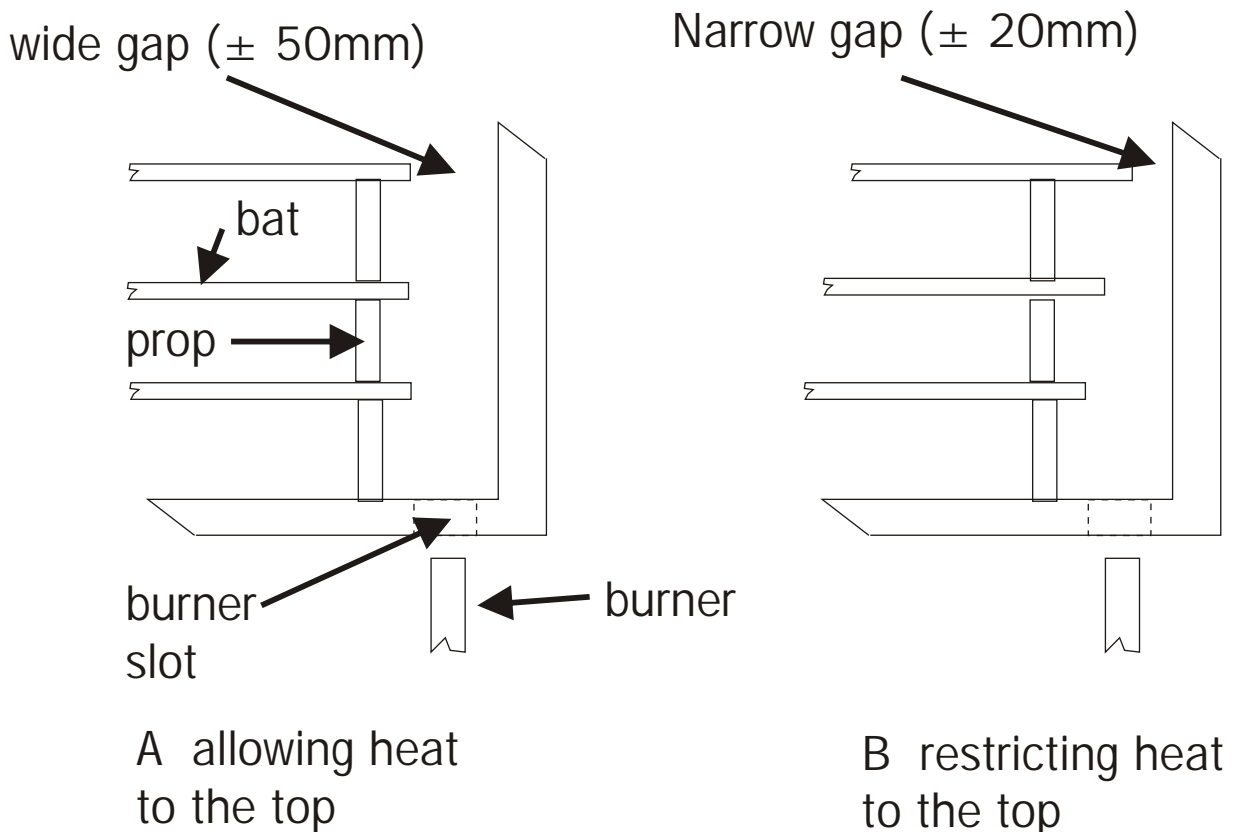

## SUGGESTED SHELF LAYOUT

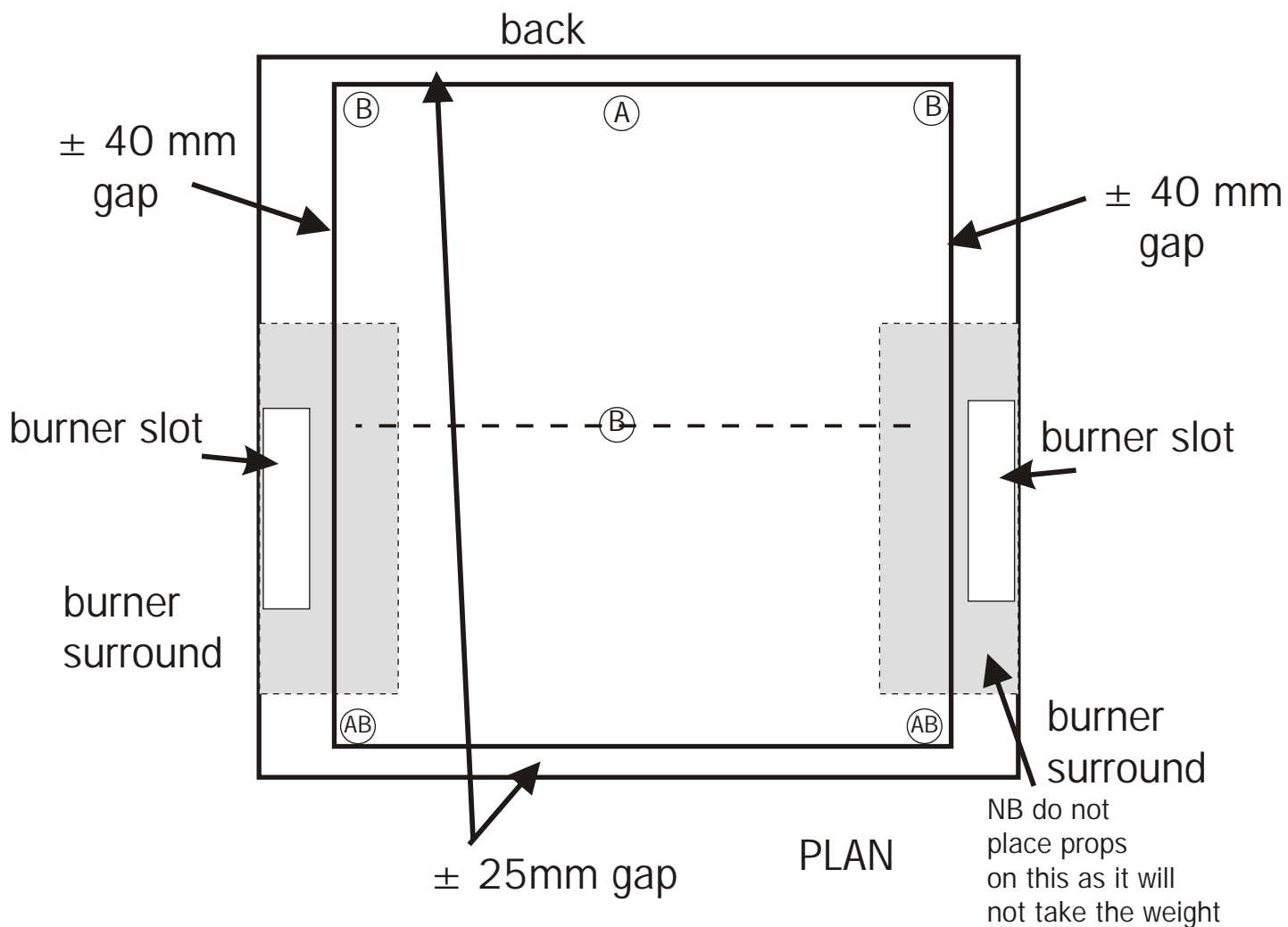

- A = position of props using full bats (3 props per level)  
 B = position of props using half bats (5 props per level)

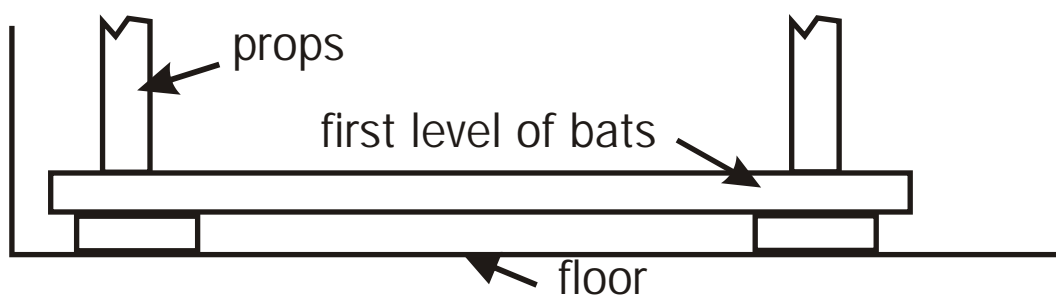

FRONT VIEW

# BURNER SYSTEM AND CONTROLS

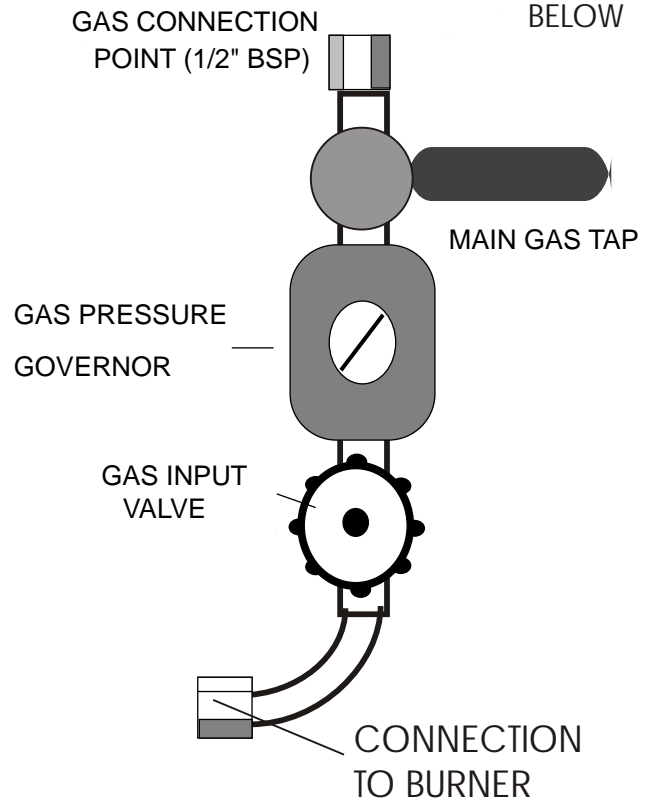
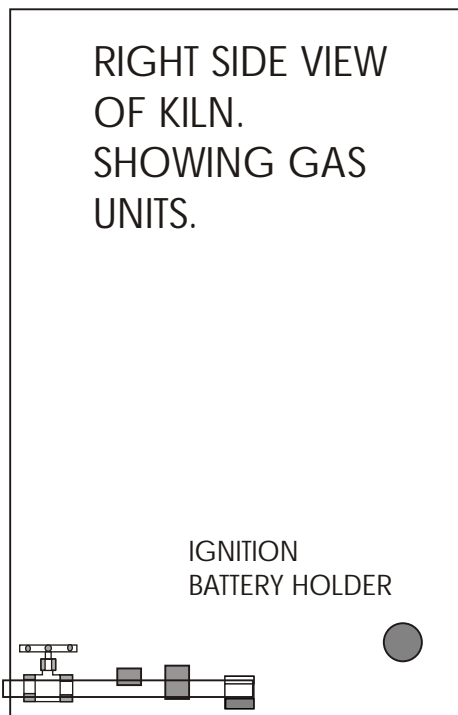
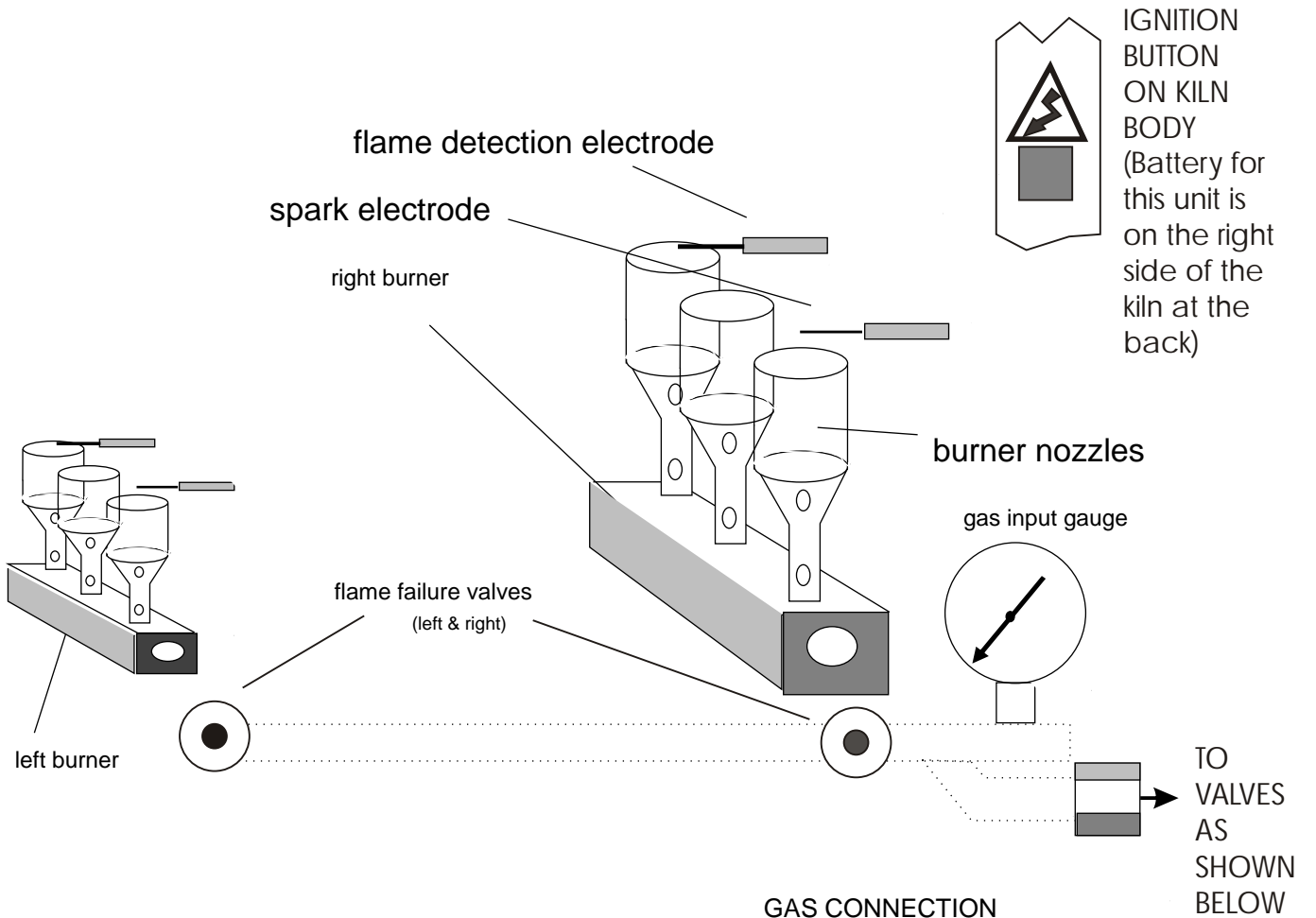

TOP VIEW OF SIDE CONNECTION PIECES.

# LIGHTING THE BURNER

## **NB THE FIRING SHOULD BE SUPERVISED AT ALL TIMES.**

Always open the door when lighting the kiln. This is to allow any unburnt gas to leave the kiln rather than build up

- 1) Turn the gas on at main tap.
- 2) Turn the input valve on a small amount (about 1/4 of a turn).
- 3) Press the right flame failure button down and at the same time press the ignition button.
- 4) If it does not light immediately do not keep the flame failure button held down. This would allow unburnt gas to build up inside the kiln.
- 5) If the burner does not light immediately repeat but always allow time for any unburnt gas to leave the kiln. Do not carry out this operation for more than 4 times without leaving the kiln for a few minutes.
- 6) The ignition button may be released as soon as the burner is lit, but hold down the flame failure button for about 20 secs. after the burner has lit.
- 7) The ignition button may be released as soon as the burner is lit.
- 8) Repeat for left burner.
- 9) The door should be closed slowly to avoid blowing out the burner. Check that it is still alight after this.



## THE FIRST FIRING

The first firing is like no other firing. A slow temperature rise to about 1000° C is necessary to dry the kiln out and burn off any resin in the ceramic fibre. During this firing a large amount of smoke will be given off. This is quite normal- it's resin burning off. It is harmless but somewhat irritating to the eyes. The firing should be carried out in a well ventilated room. The flue dampers should be left off during this firing. It is quite feasible to bisque fire pots in this firing as the smoke will not harm them. The next firing can be a normal one. Remember to adjust the door (see separate page).

## BISQUE AND RAW FIRING

The flame should be kept as small as possible at the beginning for a slow temperature rise. This pressure may not show on the pressure gauge. If the flame is very small it may burn back to the jet, and this is NOT dangerous. The flame may go out due to the flame failure probe not getting hot enough. If so relight the burner.(It will not be necessary to open the kiln door as no unburnt gas will have entered the kiln.) For dry pots 0-200 °C in two hours is a typical bisque firing rate. Two points should be remembered: 1) Gas kilns tend to show a faster rate of climb compared to electric kilns. Usually this will not damage the pots. 2) If difficulty is experienced keeping the first 200°C slow enough, turn the burner off and then wait 10 minutes before relighting to keep a rate climb to approx. 100° / hour. A typical bisque firing would be 0-200°C in two hours, 200-600°C in two and a half hours, 600-1000°C in one hour. Total time five and a half hours. The dampers should be left off the kiln during a bisque firing. It is important to remember that the pressure gauge is meant only as a guide to gas input. The best indications are flame size and temperature rise as indicated by the pyrometer. Always keep a log of all firings noting A) Time B) Temperature C) Gas pressure D) Damper settings and turbo kilns only E) Air control setting F) Rate of climb (In °/min.) For raw glaze firing after having reached 1000°C continue as per Oxidised or reduction firing.

## OXIDISED FIRING

In certain respects oxidised firing presents more difficulties than reduction firings so unless you specifically require this type of firing it is best to start with a reduction firing. A balance must be reached between the dampers being too far open and too far closed. If the dampers are open too much this will cause the heat to leave the kiln too quickly. Although this will give a oxidising atmosphere it will also cause uneven temperature inside the kiln. If the dampers are closed too much a reducing atmosphere will result. To find the correct damper setting proceed as follows: Take the temperature up to about 1000°C. Make a note of the climb (In degree/minute) as indicated on the digital pyrometer. Without altering the gas setting slowly slide the dampers in until the fastest rate of climb is found. This again is measured with the digital pyrometer. At this point if the damper is slid a further 25mm/1" the rate of climb will slow down (due to the reducing atmosphere). if the damper is withdrawn 25mm/1" the rate of climb will slow down (due to an over oxidising atmosphere.) Although this is a rather laborious procedure it need only be carried out for the first few oxidised firings, providing notes are made and proper logs kept. From about 1000°C to final cut off the rate of climb should not exceed 120°/Hour (2°/Min) otherwise the body and glaze will not have time to mature. If the rate of climb is either too fast or too slow (after having found the fastest climb re-damper setting) the gas input will need resetting. (Either more or less gas) of cause having set a new gas pressure it will be necessary to reset the dampers using the same procedure. A small flame rather than NO flame at the spy hole should be aimed for.

Take the temperature up until reduction is required. (e.g. 1000°C). Darken the room if possible, then remove the spy hole bung(s) in the kiln door. Slowly slide the damper bricks across to partially cover the flue opening. NB Always use kiln gloves for this operation. Move the dampers across approx. 12mm/1/2" every minute until a small flame (about 25mm/1") appears out of the spy hole. This can be difficult to see until higher temperatures are reached (1150°C or more). If difficulty is experienced hold a small piece of wood (e.g. spent match) in front of the spy hole. If this burns with a small flame being blown out of the kiln reduction is taking place. If not or the flame is being pulled back into the kiln oxidation is taking place. At this point the temperature will slow down. This is normal. If the temperature stays constant or drops this indicates that there is too much reduction, in which case the dampers should be slowly moved back until the temperature starts to rise. If the temperature climb continues at the same rate or nearly the same rate as before this indicates that there is too little reduction. If you have a digital pyrometer an easier method is as follows:- When reduction is required (e.g. 1000°C) the kiln will be climbing at approx. 4-6 degrees per minute (this can be seen by counting the units on the pyrometer against a watch). The pressure gauge will be at or near its maximum. (Check what this should be for your model). Next slide the dampers across until the temperature climb drops to approx. 2 degrees per minute i.e. without altering the pressure at the needle valve. This will give a medium reduction. Always wait a couple of minutes after one alteration for the kiln to settle down. During the rest of the firing a balance should be reached between gas pressure, damper setting, and temperature rise. If the pressure is increased the dampers should be withdrawn slightly. At least two hours should be allowed for this period (1000 - 1260) for the glaze to mature. NB Always replace the spy hole bung after checking the cones or reduction flame. Always use safety goggles or filter when looking in the spy hole. This protects the eyes and makes cone sighting easier. The flue is marked in 1"/25mm segments to simplify damper setting measurement.

## END OF THE FIRING

Turn off the gas at the bottle first (Propane models) then turn off the needle valve at the burner. If a slow cool down is required completely cover the flue opening, if not uncover.

## RELIGHTING A HOT KILN

Care should be taken during this operation. If the gas bottle runs out in the middle of a firing proceed on separate page 'gas bottle change over system'. If you do not have this system proceed as follows:

Turn off the empty gas bottle, Turn on the full gas bottle tap. If the kiln is red hot (above 850°C) the gas will automatically re-ignite when entering the kiln. Light the burner in the usual way. Be careful not to allow a lot of gas into the kiln. If difficulty is experienced light with a match, first completely covering the flue exit with the dampers if necessary (Do not turn the needle valve up until the dampers are removed). FURTHER INFORMATION Any further information regarding the kiln and its firing is only a phone call away.

## CARE OF THE KILN

Your kiln like any other piece of machinery may require attention occasionally. The lining may develop small cracks after a few firings (as does a brick kiln). This is because at high temperatures the material expands and then contracts. These cracks are purely the material making its own expansion joints and are nothing to worry about. Should repairs be required, inexpensive repair kits are available or repairs can be carried out by us.

## Typical Firing Log

**Firing.** Glaze

**Cones.** 7, 8, 9

TIME	TEMP ° C	CHIMNEY OPENING	GAS PRESSURE	REDUCTION FLAME SIZE	RATE OF CLIMB °/hr	remarks
10.00	20	full	none		kiln lit	
10.30	300	full	3 mbar	none	10°/hr	gas turned up
11.00	500	full	7 mbar	none	7	gas turned up
11.30	650	full	10 mbar	none	5	gas turned up
12.00	950	full	15 mbar	none	10	gas turned up
12.15	1020	15cm	15	1 cm	5	dampers set
12.30	1060	14 cm	15	2.5 cm	3	dampers moved in
12.45	1070	14 cm	15	7.5 cm	0.6	gas turned up
12.55	1065	15 cm	15	5 cm	0.5	dampers moved out
13.15	1120	15 cm	17	5 cm	3	
13.30	1170	15	17	5	3	
13.45	1210	15	17	5	2	1st cone bending
14.00	1250	15	19	5	2	gas turned up
14.15	1270	15	19	5	1	2nd cone bending
14.30	1285	15	19	5	0.5	3rd cone bending
14.40	1285	closed	0			kiln turned off, chimney covered, gas bottle off.

**The gas pressures, chimney damper setting, time/temperature increase shown on this log are as a guide only. These will vary for different kilns, type of firing etc.**



The two most common ways of measuring temperature in a kiln are cones and pyrometers. The two systems are complimentary and for reliable firing both should be used. The pyrometer directly measures the temperature in the kiln. This information is important for these situations 1) Rate of temperature climb. How quickly the temperature is going up (or down). This is particularly important during a bisque firing. 2) When to reduce. 3) Amount of reduction. If the temperature starts to fall this is one indication that the kiln is over reducing. If the temperature continues to climb at the same rate (as before setting the flue dampers) this is one indication that reduction is too light. 4) As an indication of when the firing is complete. 5) To indicate when the kiln is cool enough to open. The cones tell you exactly when the glaze is mature .

Cones measure what is known as heat work. That is temperature and time. E.g. Cone 8 might bend at (say) 1269°C if the kiln is fired at 200°C per hour but will bend at 1290°C if fired at 400°C per hour . Therefore the cones always behave in exactly the same way as the glaze. (Unlike a pyrometer).

The other point is reduction. A reducing atmosphere will make a cone bend at a lower temperature than an oxidising one. This is because the fluxes are more active under reduction (as in a glaze). The heavier a reduction, the lower the cones will bend (and the glaze will mature). It has been known for a cone 8 to bend at 1160°C in heavy reduction. Although 1230°C is more common for a normal reduction.

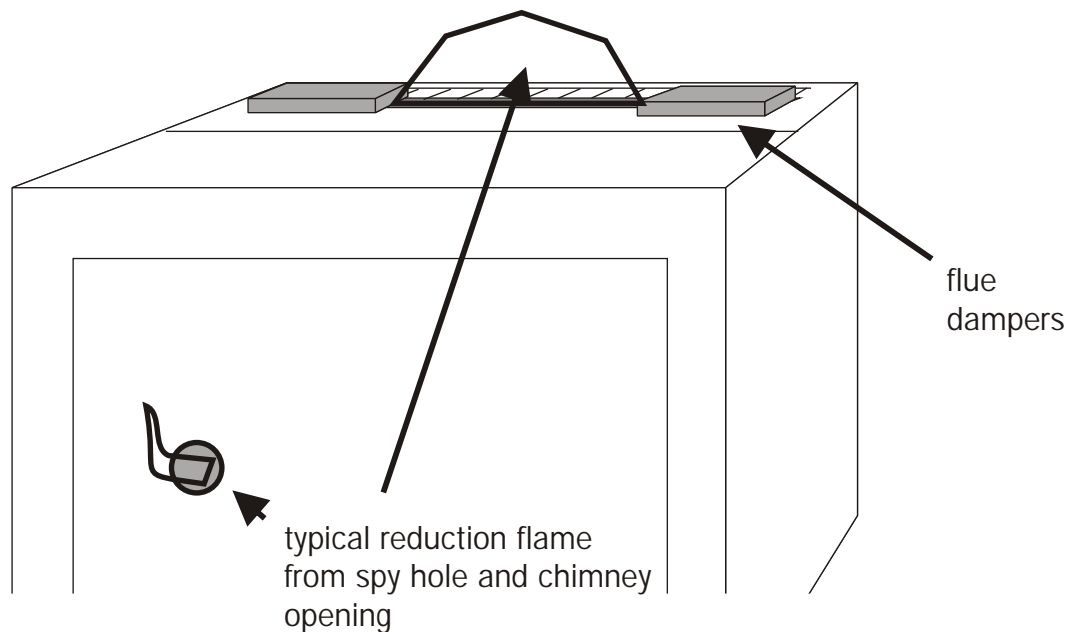

So it is strongly advised to use three cones. One cone just below maturing point as an early warning. One at maturing point. And one just above as a guide. getting the right point for a good glaze is critical.

# DOOR ADJUSTMENT

The door is locked into place for transit by a locking nut behind the thumbscrews(B). This should be loosened by using a 13mm spanner. Then the thumbscrew can be taken off to allow the locknut to be removed. The door is then secured for normal use with the thumbscrew. The thumbscrew should only be turned about a full turn after taking up the slack. Over-tightening the thumbscrew will cause compression of the door seals. The hinges have two sets of adjustment nuts. 1) The four screws (D) on the kiln body (or frame). These are used to level the door and should not normally need adjusting. 2) The four screws (C) on the edge of the door. These are used to adjust for shrinkage of the hot face walls. These will need adjusting after the first few firings, but rarely if ever again. To adjust use two medium screwdrivers. One to loosen the two screws and the other to hold the plate in position(E). When this is done, gently press on the face of the door to take up the slack. Repeat for the second hinge. Check that the door is closing with a parallel gap at the top(A). It is normal for red to be seen around the door when the kiln is firing. However if excessive red can be seen on one side this indicates that the hinges need adjusting (if on the left side) or the thumbscrews are not tight enough (if on the right side). NB always adjust when cool.

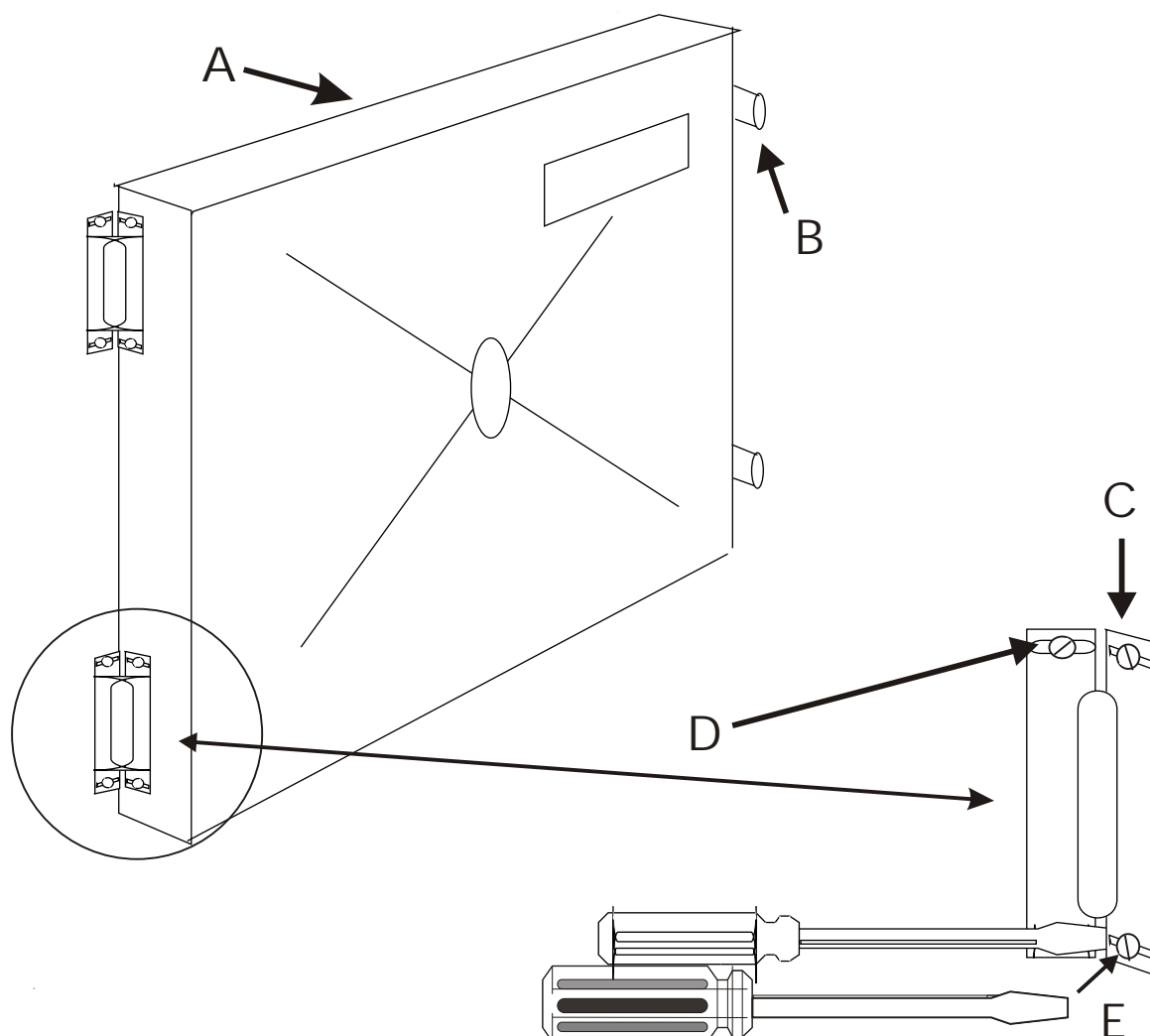

## CHIMNEY RESETTING

The chimney on your kiln is made of panels of ceramic fibre board. The joint between these boards is of a staggered design to prevent the heated air passing through. After the first few firings these gaps will open up a small amount. If the gap opens more than approx. 3/4"/20mm the chimney should be reset. To do this carefully lift up the bottom panel of one side of the chimney. This will close the gaps. **DO NOT USE FORCE.** This will break the panel. Only use a very small lifting pressure with one hand. If the gaps do not close completely this does not matter.

Next pack under the chimney support with a small piece of ceramic fibre blanket.

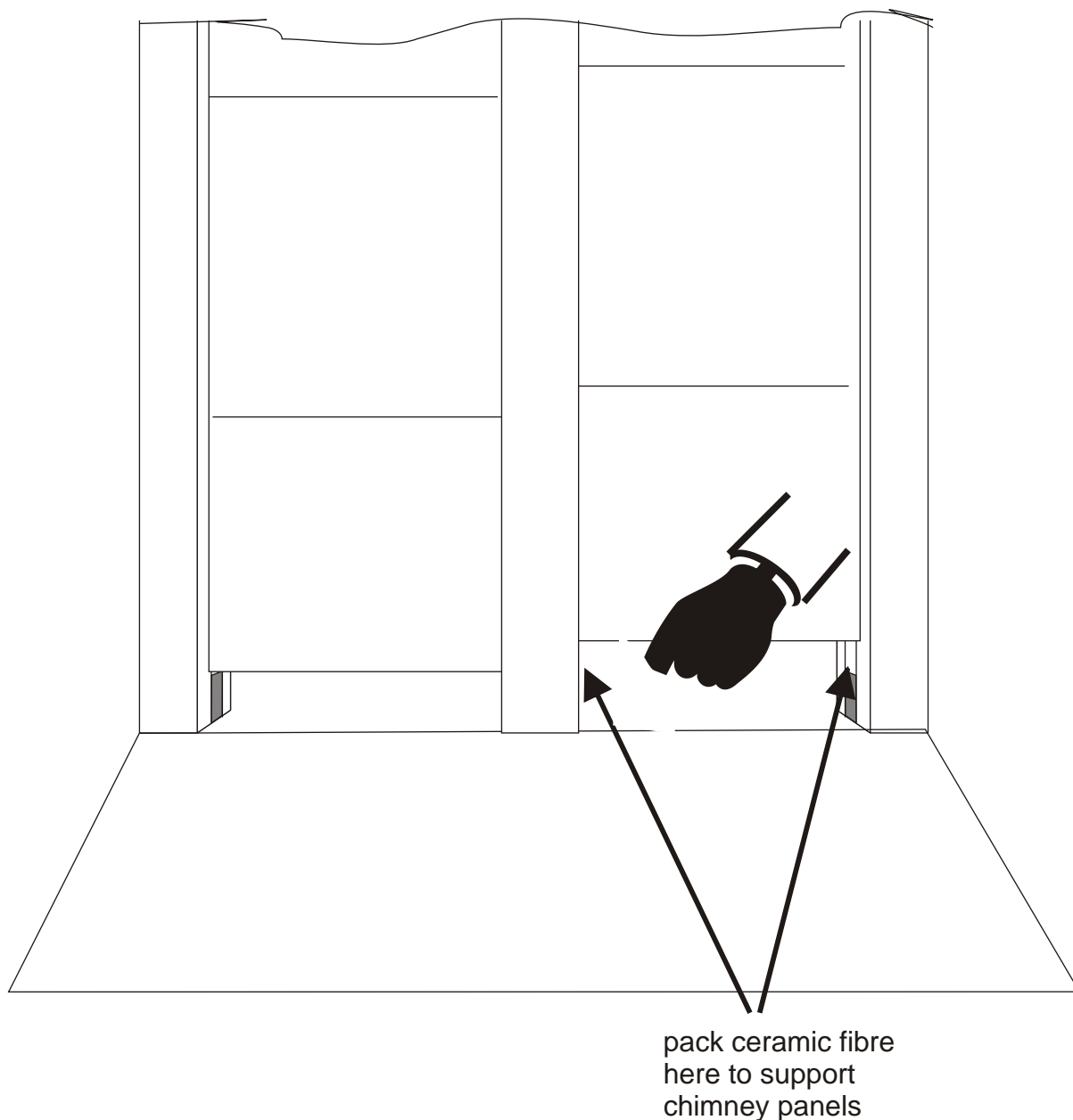

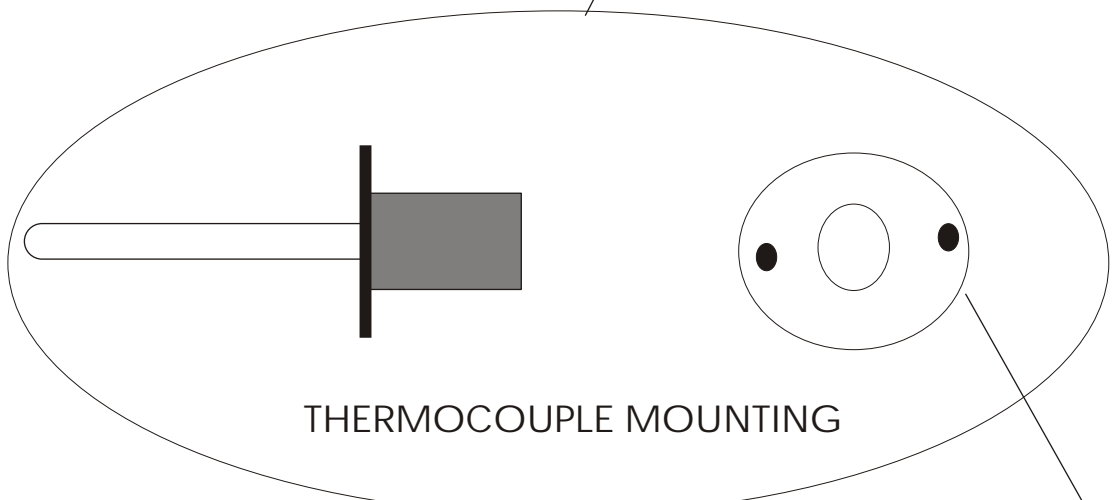
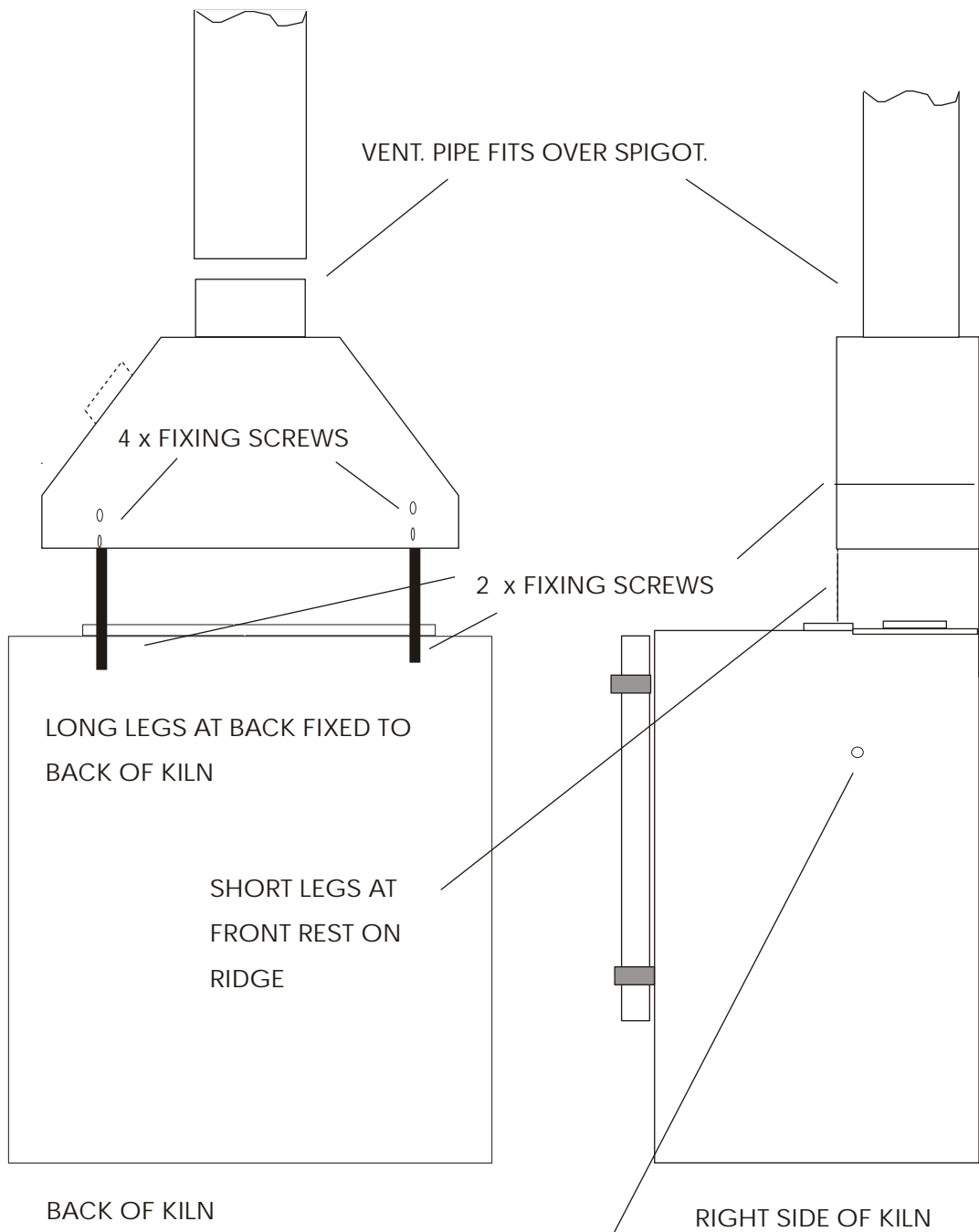

HEAT FUSE (IF SUPPLIED) IS FITTED IN SAME WAY BESIDE THERMOCOUPLE.